

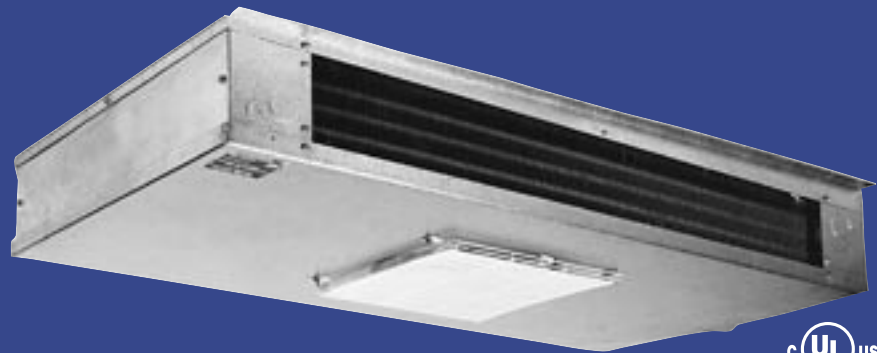

Bulletin LW-03
February 2003
Replaces LW-96A • 4/01

Low Velocity Center Mount Unit Coolers



ALSO CLASSIFIED
AS A COMPONENT
IN ACCORDANCE
WITH NSF 7 - 1999

LWA - Air Defrost
LWE - Electric Defrost
LWG - Hot Gas Defrost

LW Series

The LW Series is ideal for floral storage, fresh fruit and vegetables, dough retarding, fresh meat storage and preparations, and many other applications (24°F. and above). The low air flow and quiet fans are ideal for work room applications. The generous coil surface combined with close T.D. system balance provides high humidity characteristics to minimize product shrinkage and drying. LW Series units are available in air, electric and hot gas defrost.

Features

- Enhanced tubing for optimum efficiency
- Galvanized motor rail provides maximum strength and durability
- Wire fan guards with PVC coating
- Fan panel hangs from unit for easy servicing and installation - one person can easily install and service
- Efficient terminal board design simplifies wiring between the evaporator and condensing unit
- Solenoid wiring harness is factory installed for easy installation
- Sweat connections to reduce potential for leaks
- Low height of the LW series makes it ideal for low ceiling coolers. Larger models are only 15 inches tall to allow for maximum head room and more product storage
- The LW series has a heavy gauge, attractive grained aluminum housing with stainless steel fasteners
- Coils are dehydrated and sealed at the factory
- LWE electric defrost models incorporate high quality tubular heaters and a defrost termination control factory set and wired
- Unit designed to be mounted flush against the ceiling or suspended on rods
- Access panels on each end make expansion valve installation and electrical hookup easy
- Motors are permanently lubricated and thermal overload protected
- Fan panel is lightweight and can easily be lowered if internal inspection is required
- A double drain pan eliminates drain pan sweating
- All LW Series units are UL listed for U.S.A. and Canada and meet NSF standards

Options

- PSC motors are required for 50Hz operations and are an option for 60 Hz operations
- Expansion valve mounts inside the cabinet
- Contact your Larkin sales representative for additional options that are available

Nomenclature

LW	E	100	B	C
LW = Larkin Low Air Flow Unit Cooler	Defrost Designation: A = Air E = Electric G = Hot Gas	Voltage: A = 115/1/60 B = 208-230/1/60	Capacity: x100 = BTUH (10°F TD)	Vintage

Model No.	Capacities BTUH / kcal				Fan Data		Motor Data				Approx. Net Weight (Lbs / kg)
	10° F TD 6° C TD	15° F TD 8° C TD	50-55° F. DB 55% RH 20° TD				Shaded Pole (Std)		PSC (Opt.)		
			Total	Sensible	No.	CFM/m ³ h	115/1/60 Amps	208-230/1/60 Amps	115/1/60 Amps	208-230/1/60 Amps	
LWA 050	5000 1260	7500 1890	10000 2520	8500 2142	1	725 1233	2.1	1.1	0.9	0.45	70 32
LWA 075	7500 1890	11250 2835	15000 3780	12750 3213	1	730 1241	2.1	1.1	0.9	0.45	103 47
LWA 100	10000 2520	15000 3780	20000 5040	17000 4284	2	1450 2465	4.2	2.2	1.8	0.9	106 48
LWA 130	13000 3276	19500 4914	26000 6552	22100 5569	2	1470 2499	4.2	2.2	1.8	0.9	145 66
LWA 155	15500 3906	23250 5859	31000 7812	26350 6640	2	1460 2482	4.2	2.2	1.8	0.9	149 68
LWA 180	18000 4536	27000 6804	36000 9072	30600 7711	3	2130 3621	6.3	3.3	2.7	1.35	160 73
LWA 210	21000 5292	31500 7938	42000 10584	35700 8996	4	2840 4828	8.4	4.4	3.6	1.8	193 88
LWA 270	27000 6804	40500 10206	54000 13608	45900 11567	4	2800 4760	8.4	4.4	3.6	1.8	200 91
LWA 340	34000 8568	51000 12852	68000 17136	57800 14566	5	3500 5950	10.5	5.5	4.5	2.25	242 110

Model No.	Capacities BTUH / kcal				Fan Data		Motor Data		Approx. Net Weight (Lbs / kg)
	10° F TD 6° C TD	15° F TD 8° C TD	10-13° C. DB 55% RH 20° TD				PSC (standard)		
			Total	Sensible	No.	CFM/m ³ h	110/1/50 Amps	220/1/50 Amps	
LWA 050	4800 1210	7100 1790	9500 2390	8100 2040	1	660 1122	0.9	0.45	70 32
LWA 075	7100 1790	10700 2700	14300 3600	12100 3050	1	660 1122	0.9	0.45	103 47
LWA 100	9500 2390	14300 3600	19000 4790	16200 4080	2	1310 2227	1.8	0.9	106 48
LWA 130	12400 3120	18500 4660	24700 6220	21000 5290	2	1330 2261	1.8	0.9	145 66
LWA 155	14700 3700	22100 5570	29500 7430	25000 6300	2	1320 2244	1.8	0.9	149 68
LWA 180	17100 4310	25700 6480	34200 8620	29100 7330	3	1920 3264	2.7	1.35	160 73
LWA 210	20000 5040	29900 7530	39900 10050	33900 8540	4	2560 4352	3.6	1.8	193 88
LWA 270	25700 6480	38500 9700	51300 12930	43600 10990	4	2530 4301	3.6	1.8	200 91
LWA 340	32300 8140	48500 12220	64600 16280	54900 13830	5	3160 5372	4.5	2.25	242 110

Electrical Data - Electric Defrost

Model No.	Capacities BTUH / kcal		Fan Data		Motor Data		Heaters		Approx. Net Weight (Lbs/kg)
	10° F TD	15° F TD	Qty	CFM/m ³ h	Shaded Pole (Std)	PSC (Optional)	Total Watts	230/1/60 Amps	
	6° C TD	8° C TD			230/1/60 Amps	230/1/60 Amps			
LWE 050	5000 1260	7500 1890	1	725 1233	1.1	0.45	2000	8.7	75 34
LWE 075	7500 1890	11250 2835	1	730 1241	1.1	0.45	2400	10.5	108 49
LWE 100	10000 2520	15000 3780	2	1450 2465	2.2	0.9	2800	12.2	111 50
LWE 130	13000 3276	19500 4914	2	1470 2499	2.2	0.9	4000	17.4	150 68
LWE 155	15500 3906	23250 5859	2	1460 2482	2.2	0.9	4000	17.4	154 70
LWE 180	18000 4536	27000 6804	3	2130 3621	3.3	1.35	4000	17.4	157 71
LWE 210	21000 5292	31500 7938	4	2840 4828	4.4	1.8	5200	22.6	203 92
LWE 270	27000 6804	40500 10206	4	2800 4760	4.4	1.8	5200	22.6	208 94
LWE 340	34000 8568	51000 12852	5	3500 5950	5.5	2.25	7000	30.4	250 113

Model No.	Capacities BTUH / kcal		Fan Data		Motor Data	Heaters		Approx. Net Weight (Lbs/kg)
	10° F TD	15° F TD	Qty	CFM/m ³ h	PSC (Optional)	Total Watts	220/1/50 Amps	
	6° C TD	8° C TD			220/1/50 Amps			
LWE 050	4800 1210	7100 1790	1	660 1122	0.45	1830	8.3	75 34
LWE 075	7100 1790	10700 2700	1	660 1122	0.45	2200	10.0	108 49
LWE 100	9500 2390	14300 3600	2	1310 2227	0.9	2560	11.6	111 50
LWE 130	12400 3120	18500 4660	2	1330 2261	0.9	3660	16.6	150 68
LWE 155	14700 3700	22100 5570	2	1320 2244	0.9	3660	16.6	154 70
LWE 180	17100 4310	25700 6480	3	1920 3264	1.35	3660	16.6	157 71
LWE 210	20000 5040	29900 7530	4	2560 4352	1.8	4760	21.6	203 92
LWE 270	25700 6480	38500 9700	4	2530 4301	1.8	4760	21.6	208 94
LWE 340	32300 8140	48500 12220	5	3160 5372	2.25	6400	29.1	250 113

Model No.	Capacities BTUH / kcal		Fan Data		Motor Data				Drain Pan Heaters			Approx. Net Weight (Lbs / kg)
	10° F TD 6° C TD	15° F TD 8° C TD	Qty.	CFM/m ³ h	Shaded Pole (Std)		PSC (Opt.)		Total Watts	115/1/60 Amps	208-230/1/60 Amps	
					115/1/60 Amps	208-230/1/60 Amps	115/1/60 Amps	208-230/1/60 Amps				
LWG 100	10000 2520	15000 3780	2	1450 2465	4.2	2.2	1.8	0.9	350	3	1.5	131 59
LWG 130	13000 3276	19500 4914	2	1470 2499	4.2	2.2	1.8	0.9	500	4.4	2.2	170 77
LWG 155	15500 3906	23250 5859	2	1460 2482	4.2	2.2	1.8	0.9	500	4.4	2.2	174 79
LWG 180	18000 4536	27000 6804	3	2130 3621	6.3	3.3	2.7	1.35	500	4.4	2.2	185 84
LWG 210	21000 5292	31500 7938	4	2840 4828	8.4	4.4	3.6	1.8	650	5.7	2.8	223 101
LWG 270	27000 6804	40500 10206	4	2800 4760	8.4	4.4	3.6	1.8	650	5.7	2.8	228 103
LWG 340	34000 8568	51000 12852	5	3500 5950	10.5	5.5	4.5	2.25	875	7.6	3.8	270 122

Model No.	Capacities BTUH / kcal		Fan Data		Motor Data		Heaters			Approx. Net Weight (Lbs/kg)
	10° F TD 6° C TD	15° F TD 8° C TD	Qty.	CFM/m ³ h	PSC (Optional)		Total Watts	220/1/50 Amps	110/1/50 Amps	
					110/1/50 Amps	220/1/50 Amps				
LWG 100	9500 2390	14300 3600	2	1310 2227	1.8	0.9	320	1.5	2.9	131 59
LWG 130	12400 3120	18500 4660	2	1330 2261	1.8	0.9	460	2.1	4.2	170 77
LWG 155	14700 3700	22100 5570	2	1320 2244	1.8	0.9	460	2.1	4.2	174 79
LWG 180	17100 4310	25700 6480	3	1920 3264	2.7	1.35	460	2.1	4.2	185 84
LWG 210	20000 5040	29900 7530	4	2560 4352	3.6	1.8	595	2.7	5.4	223 101
LWG 270	25700 6480	38500 9700	4	2530 4301	3.6	1.8	595	2.7	5.4	228 103
LWG 340	32300 8140	48500 12220	5	3160 5372	4.5	2.25	800	3.6	7.3	270 122

Optional Liquid Line Bypass Kit For Reverse Cycle Hot Gas Defrost

The LWG may be field piped for reverse cycle defrost using the optional bypass kit.

When compressor vapor, in reverse cycle defrosting, is directed back into the evaporator at the suction connection, it condenses into liquid. The field installed liquid line bypass kit directs the condensed liquid around the thermostatic expansion valve and back into the liquid line.

Bypass kits include bypass piping, check valve, and instructions. Adjustable fan control is shipped loose with hot gas units.

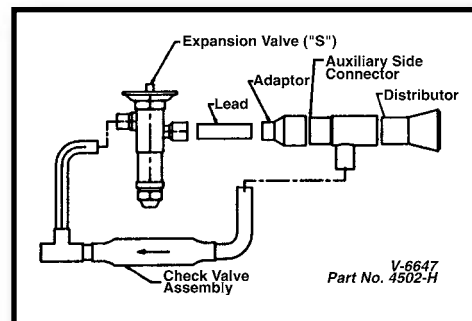

Dimensions & Replacement Parts

Dimensions for all LW Series Units

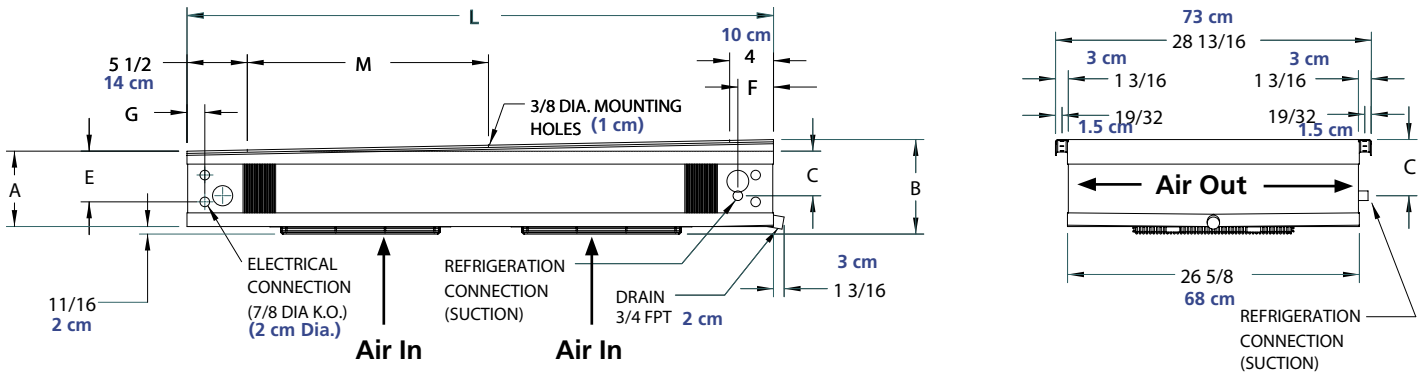

Dimensional Data for all LW Series Units

Model Numbers by Defrost Types			Dimensions (Inches/)								Connections (In.)	
Air	Electric	Hot Gas	A	B	C	D	E	F	G	L	Liquid OD	Suction OD
LWA 050	LWE 050	—	6-7/8 17	8-7/8 23	4-1/16 10	—	4-5/8 12	3-1/4 8	1-5/8 4	53-1/2 136	1/2	7/8
LWA 075	LWE 075	—	6-7/8 17	8-7/8 23	4-1/16 10	—	4-5/8 12	3-1/4 8	1-5/8 4	75-1/2 192	1/2	7/8
LWA 100	LWE 100	LWG 100	9-3/8 24	11-3/8 29	6-9/16 17	—	7-1/8 18	3-1/4 8	1-5/8 4	75-1/2 192	1/2	7/8
LWA 130	LWE 130	LWG 130	13-1/8 33	15-1/8 38	10-1/8 26	—	8-1/2 22	2-11/16 7	1-1/8 3	75-1/2 192	1-1/8	1-1/8
LWA 155	LWE 155	LWG 155	13-1/8 33	15-1/8 38	10-1/8 26	—	8-1/2 22	2-11/16 7	1-1/8 3	75-1/2 192	1-1/8	1-1/8
LWA 180	LWE 180	LWG 180	13-1/8 33	15-1/8 38	10-1/8 26	—	8-1/2 22	2-11/16 7	1-1/8 3	75-1/2 192	1-1/8	1-1/8
LWA 210	LWE 210	LWG 210	13-1/8 33	15-1/8 38	10-1/8 26	44 112	8-1/2 22	2-11/16 7	1-1/8 3	97-1/2 248	1-1/8	1-1/8
LWA 270	LWE 270	LWG 270	13-1/8 33	15-1/8 38	10-1/8 26	44 112	8-1/2 22	2-11/16 7	1-1/8 3	97-1/2 248	1-3/8	1-3/8
LWA 340	LWE 340	LWG 340	13-1/8 33	15-1/8 38	10-1/8 26	55 140	8-1/2 22	2-11/16 7	1-1/8 3	119-1/2 304	1-3/8	1-3/8

All units have 1/4" OD external equalizer and 3/4" F.P.T. drain connection.

Replacement Parts List

Part Description	Model Number				
	LWA050 LWE050	LWA075 LWE075	LWA100 LWE100 LWG100	LWA130 LWE130 LWG130	LWA155 LWE155 LWG155
Electrical Components					
	Part Number*				
Motor 115/1/60 Shaded Pole	5036S (1)	5036S (1)	5036S (2)	5036S (2)	5036S (2)
Motor 208-230/1/60 Shaded Pole	5036T (1)	5036T (1)	5036T (2)	5036T (2)	5036T (2)
Motor 115/1/60 or 110/1/50 PSC	5036N (1)	5036N (1)	5036N (2)	5036N (2)	5036N (2)
Motor 208-230/1/60 or 220/1/50 PSC	5036P (1)	5036P (1)	5036P (2)	5036P (2)	5036P (2)
Defrost termination switch "LWE"	4511C	4511C	5521R	5521R	5521R
Heater**	4401S (2)	4402S (2)	4543B (4)	4544B (4)	4544B (4)
Fan Components					
Fan Blade	5110E (1)	5110E (1)	5110E (2)	5110E (2)	5110E (2)
Fan Guard	23102101	23102101	23102101	23102101	23102101
Cabinet Components					
Fan Panel / Drain Pan	40842703	40842803	40842903	40842903	40842903
Inner drain pan assembly: Air Defrost	B25196A1	B25197A1	B25197A1	B25197A1	B25197A1
Inner drain pan: Electric & Hot Gas Defrost	B24358A7	B24358A7	B24358A7	B24358A7	B24358A7
End panel (2 per unit)	B24264A1	B24264A1	C26767A1	C26768A1	C26768A1
Side panel (4 per unit)	A20673A1	A20673A1	B24493A1	B24494A1	B24494A1

Replacement Parts & Nozzle Selections

Part Description	Model Number			
	LWA180 LWE180 LWG180	LWA210 LWE210 LWG210	LWA270 LWE270 LWG270	LWA340 LWE340 LWG340
Electrical Components		Part Number*		
Motor 115/1/60 Shaded Pole	5036S (3)	5036S (4)	5036S (4)	5036S (5)
Motor 208-230/1/60 Shaded Pole	5036T (3)	5036T (4)	5036T (4)	5036T (5)
Motor 115/1/60 or 110/1/50 PSC	5036N (3)	5036N (4)	5036N (4)	5036N (5)
Motor 208-230/1/60 or 220/1/50 PSC	5036P (3)	5036P (4)	5036P (4)	5036P (5)
Defrost termination switch "LWE"	5521R	5521R	5521R	5521R
Heater**	4544B (4)	4545B (4)	4545B (4)	4546B (4)
Fan Components				
Fan Blade	5110E (3)	5110E (4)	5110E (4)	5110E (5)
Fan Guard	23102101	23102101	23102101	23102101
Cabinet Components				
Fan Panel / Drain Pan	40849203	40849303	40849303	40849403
Inner drain pan assembly: Air Defrost	B25197A1	B25198A1	B25198A1	C26774A1
Inner drain pan: Electric & Hot Gas Defrost	B24358A7	B24358A8	B24358A8	B24358A9
End panel (2 per unit)	C26768A1	C26768A1	C26768A1	C26768A1
Side panel (4 per unit)	B24494A1	B24494A1	B24494A1	B24494A1

FOR UNITS PRIOR TO "C" REVISION, PLEASE CONSULT FACTORY.

* Number in parenthesis is quantity per unit.

** All hot gas models have two heaters.

Standard Nozzle Selections (included with unit for field installation)

Type	No. of Fans	Distributor Tube Length	Model	No. of Circuits	Nozzles	
					R-404A**	R-22
LWA Air Defrost	1	18	50	2	L- 1/2	L- 1/3
			75	4	L- 3/4	L- 1/2
	2	18	100	6	L- 1	L- 3/4
			130	12	E- 1 1/2	E- 1
			155	10	E- 2	E- 1
	3	24	180	12	E- 2	E- 1 1/2
			210	12	E- 2 1/2	E- 1 1/2
	4	24	270	20	C- 3	C- 2
			340	20	C- 4	C- 2 1/2
	LWE Electric Defrost and LWG Hot Gas Defrost	1	18	50	2	L- 1/2
75				4	L- 1	L- 3/4
2		18	100	6	L- 1 1/2	L- 3/4
			130	12	E- 1 1/2	E- 1
			155	10	E- 2	E- 1 1/2
3		24	180	12	E- 2	E- 1 1/2
			210	12	E- 2 1/2	E- 2
4		24	270	20	C- 3	C- 2
			340	20	C- 4	C- 2 1/2

NOTES: ** also suitable for R-507, R-502, R-134a, R-401A, R-402A.

Distributor tube O.D. = 3/16" for all models. Nozzles sized for 95° F liquid temp at expansion valve. Refer to Installation and Maintenance manual if liquid temp is not 95° F. Room temperature of 35° F for air defrost models and 28° F for electric/hot gas models. Consult your Larkin sales representative or the factory if the evaporator TD does not equal room temp - saturated suction temp.

NOTE: REFRIGERATION SYSTEM WILL NOT PERFORM PROPERLY WITHOUT CORRECT NOZZLE!

Visit our website at www.heatcraftrpd.com for technical literature online.

Since product improvement is a continuing effort at Heatcraft, we reserve the right to make changes in specifications without notice.



A Brand of Heatcraft Refrigeration Products LLC

2175 West Park Place Blvd. • Stone Mountain, GA 30087
770.465.5600 • Fax: 770.465.5990
www.heatcraftrpd.com

