



**Bulletin LC-03A**  
**August 2004**  
(Replaces LC-03 • 3/03)

## Compak Unit Coolers



**LCA - Air Defrost**  
**LCE - Electric Defrost**  
**LCH - Hot Gas Defrost**  
3,500 to 27,000 BTU/H



**Front access to refrigeration components.** Now with more space on both sides.

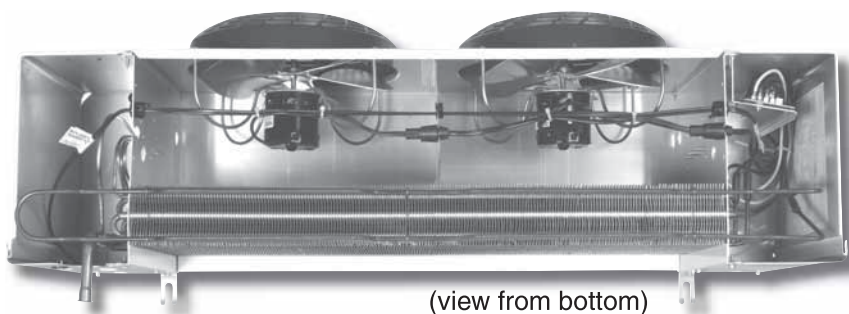
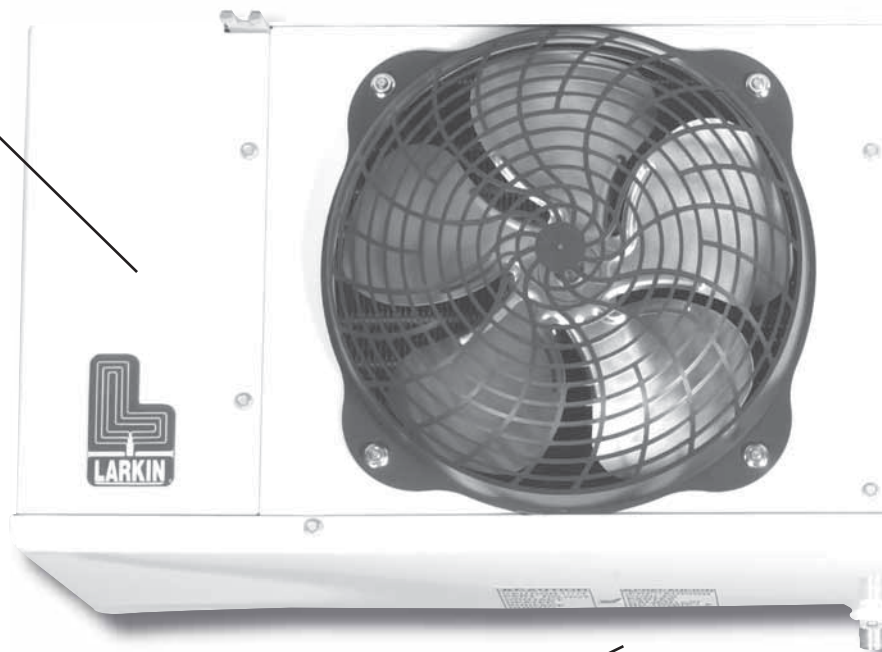

(view from bottom)

**Motor and solenoid harnesses are easier to access from the bottom of the coil.** The drain pan heater is located on the bottom of the coil, which allows the drain pan to be removed without the removal of the heater. The drain pan heater also extends into the end panels for more heat in the side panel cavities.

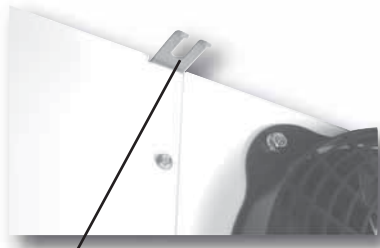

**Hanger Bars** - now powder coated for corrosion protection

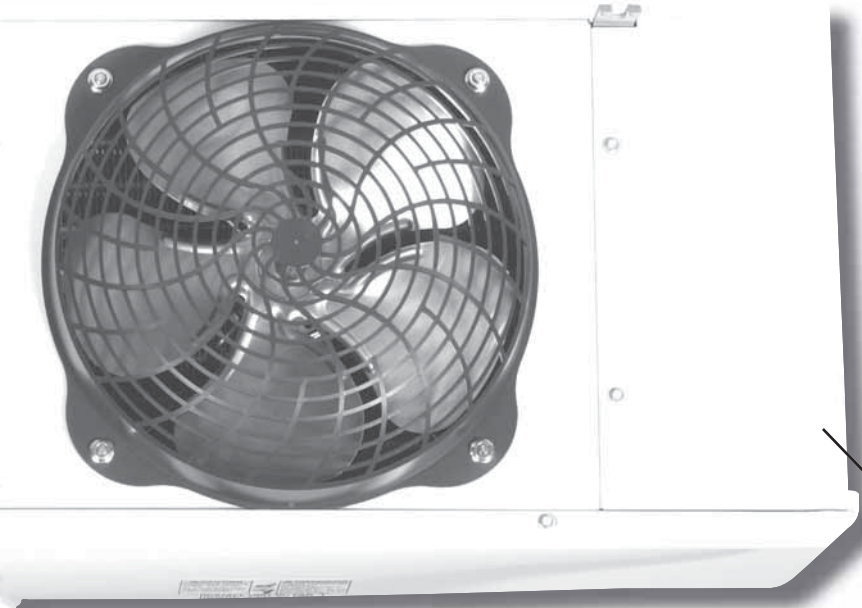

ALSO CLASSIFIED AS A COMPONENT IN ACCORDANCE WITH NSF 7 - 1999



**Drain fitting is standard** in air and electric defrost (shipped loose). This fitting allows easy removal of drain pan without removal of hard piping.

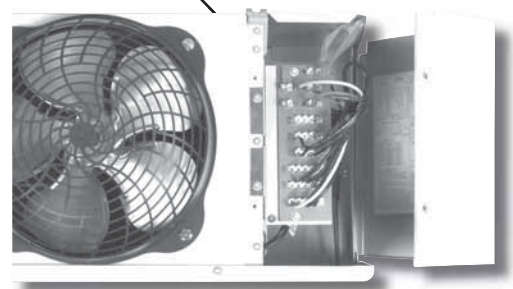

**Front facing electric board** for easy access. Optimized space in end panels.

# Standard Features

## New Features:

- **New model sizes available - New Capacities: 4,000, 4,100, 14,000 & 18,000 BTU/H**  
**Better capacity match with Larkin condensing units.**
- More space in the electrical cavity
- Electrical board is now facing forward for easy installation and servicing
- All wiring (solenoid and motor) is now located in the bottom of the unit for easy access
- New mounting brackets are now powder coated for corrosion protection

## Front Access with More Space:

- Design features easy front access to both electrical and refrigeration components
- More space in the electrical cavity makes the unit easier to service and install
- Front facing electrical control board

## Wiring:

- Solenoid harness is standard
- Motor and solenoid harnesses are attached to sheet metal panels and are now located at the bottom of the unit for easy access
- Holes in the bottom of the sheet metal panels for easier wire routing
- Easy plug connectors for motor harness

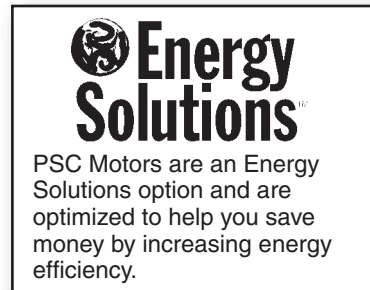

## Heaters & Coil:

- Coil heater slots have been enlarged for easier installation and replacement
- Extended drain pan heater on both end cavities for better defrost of end cavities
- Reduced heater wattage
- Fixed defrost termination on electric defrost, adjustable for hot gas
- Hot gas loop is standard for hot gas models

## New Options:

- Beacon II compatible - front panel will have a cut-out window for LED readout
- Precharged units with quick connect fittings
- Preassembled units with TXV, liquid line solenoid and room thermostat

## Other Options:

- PSC motors (standard on 460/1/60 units)
- Totally enclosed PSC motors available in 115/1/60, 208-230/1/60 and 460/1/60 voltages
- 50 Hz. units

# Model Nomenclature

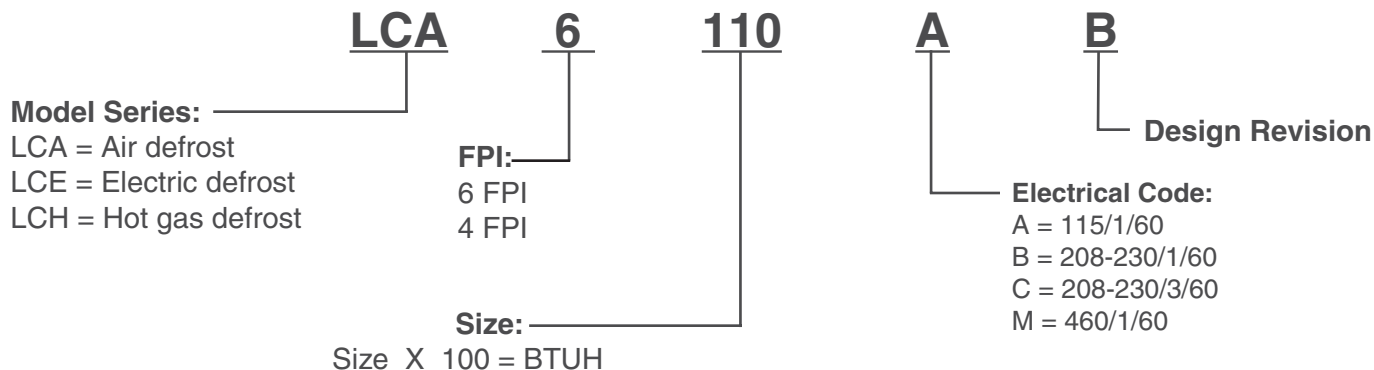

## LCA6 Air Defrost Models 60 Hz. with Shaded Pole Motors

LCA6 Model Size	Capacity BTUH / Watts 10°F TD/ 6°C TD +25°F SST/-4°C SST		Fan Data			Shaded Pole Motor Data (Total Amps/Watts)				
			CFM / m <sup>3</sup> H		No.	HP	115/ 1/60/Watts		208-230/ 1/60/Watts	
LCA640	4,000	1,170	730	1,240	1	1/15	1.8	116	1.0	122
LCA651	5,100	1,500	700	1,189	1	1/15	1.8	116	1.0	122
LCA662	6,200	1,820	650	1,104	1	1/15	1.8	116	1.0	122
LCA672	7,200	2,110	1,460	2,481	2	1/15	3.6	232	2.0	244
LCA690	9,000	2,640	1,400	2,379	2	1/15	3.6	232	2.0	244
LCA6110	11,000	3,220	1,300	2,209	2	1/15	3.6	232	2.0	244
LCA6135	13,500	3,950	2,100	3,568	3	1/15	5.4	348	3.0	366
LCA6160	16,000	4,690	1,950	3,313	3	1/15	5.4	348	3.0	366
LCA6185	18,500	5,420	2,800	4,758	4	1/15	7.2	464	4.0	488
LCA6215	21,500	6,290	2,600	4,418	4	1/15	7.2	464	4.0	488
LCA6260	26,000	7,610	3,250	5,522	5	1/15	9.0	580	5.0	610
LCA6310	31,000	9,070	3,900	6,627	6	1/15	10.8	696	6.0	732
LCA6350	35,000	10,240	3,900	6,627	6	1/15	10.8	696	6.0	732

## LCA6 Air Defrost Models 60 Hz. with PSC Motors



LCA6 Model Size	Capacity BTUH / Watts 10°F TD/ 6°C TD +25°F SST/-4°C SST		Fan Data			PSC, PSC-TE Motor Data (Total Amps/Watts)						
			CFM / m <sup>3</sup> H		No.	HP	115/ 1/60 Watts		208-230/ 1/60 Watts		460/ 1/60 Watts	
LCA640	4,000	1,170	730	1,240	1	1/15	1.0	82	0.5	91	0.4	117
LCA651	5,100	1,500	700	1,189	1	1/15	1.0	82	0.5	91	0.4	117
LCA662	6,200	1,820	650	1,104	1	1/15	1.0	82	0.5	91	0.4	117
LCA672	7,200	2,110	1,460	2,481	2	1/15	2.0	164	1.0	182	0.8	234
LCA690	9,000	2,640	1,400	2,379	2	1/15	2.0	164	1.0	182	0.8	234
LCA6110	11,000	3,220	1,300	2,209	2	1/15	2.0	164	1.0	182	0.8	234
LCA6135	13,500	3,950	2,100	3,568	3	1/15	3.0	246	1.5	273	1.2	351
LCA6160	16,000	4,690	1,950	3,313	3	1/15	3.0	246	1.5	273	1.2	351
LCA6185	18,500	5,420	2,800	4,758	4	1/15	4.0	328	2.0	364	1.6	468
LCA6215	21,500	6,290	2,600	4,418	4	1/15	4.0	328	2.0	364	1.6	468
LCA6260	26,000	7,610	3,250	5,522	5	1/15	5.0	410	2.5	455	2.0	585
LCA6310	31,000	9,070	3,900	6,627	6	1/15	6.0	492	3.0	546	2.4	702
LCA6350	35,000	10,240	3,900	6,627	6	1/15	6.0	492	3.0	546	2.4	702

# Electric Defrost Capacities

## LCE6/LCE4 Electric Defrost Models 60 Hz. with Shaded Pole Motors

LCE6/LCE4 Model Size	Capacity BTUH / Watts 10°F /6°C TD -20°F / -29°C SST		Fan Data		Shaded Pole Motor Data (Total Amps/Watts)			Defrost Heaters (Total Amps)				
			CFM / m³H	No.	HP	208-230/ 1/60 Watts	Watts	230/ 1/60	230/ 3/60	460/ 1/60		
	6 FPI Models											
LCE635	3,500	1,030	700	1,189	1	1/15	1.0	122	900	3.9	2.3	2.0
LCE643	4,300	1,260	650	1,104	1	1/15	1.0	122	900	3.9	2.3	2.0
LCE665	6,500	1,900	1,400	2,379	2	1/15	2.0	244	1800	7.8	4.5	3.9
LCE676	7,600	2,230	1,300	2,209	2	1/15	2.0	244	1800	7.8	4.5	3.9
LCE694	9,400	2,750	1,300	2,209	2	1/15	2.0	244	1800	7.8	4.5	3.9
LCE6120	12,000	3,520	2,100	3,568	3	1/15	3.0	366	2700	11.7	6.8	5.9
LCE6140	14,000	4,100	1,950	3,313	3	1/15	3.0	366	2700	11.7	6.8	5.9
LCE6160	16,000	4,690	2,600	4,418	4	1/15	4.0	488	3600	15.7	9.0	7.8
LCE6180	18,000	5,270	2,600	4,418	4	1/15	4.0	488	3600	15.7	9.0	7.8
LCE6200	20,000	5,860	3,250	5,522	5	1/15	5.0	610	4500	19.6	11.3	9.8
LCE6240	24,000	7,030	3,900	6,627	6	1/15	6.0	732	5400	23.5	13.6	11.7
LCE6270	27,000	7,900	3,900	6,627	6	1/15	6.0	732	5400	23.5	13.6	11.7
4 FPI Models												
LCE441	4,100	1,200	690	1,172	1	1/15	1.0	122	900	3.9	2.3	2.0
LCE457	5,700	1,670	1,440	2,447	2	1/15	2.0	244	1800	7.8	4.5	3.9
LCE467	6,700	1,960	1,380	2,345	2	1/15	2.0	244	1800	7.8	4.5	3.9
LCE482	8,200	2,400	1,380	2,345	2	1/15	2.0	244	1800	7.8	4.5	3.9
LCE4105	10,500	3,080	2,170	3,687	3	1/15	3.0	366	2700	11.7	6.8	5.9
LCE4139	13,900	4,070	2,760	4,690	4	1/15	4.0	488	3600	15.7	9.0	7.8
LCE4174	17,400	5,100	3,450	5,862	5	1/15	5.0	610	4500	19.6	11.3	9.8
LCE4208	20,800	6,090	4,140	7,035	6	1/15	6.0	732	5400	23.5	13.6	11.7
LCE4235	23,500	6,880	4,140	7,035	6	1/15	6.0	732	5400	23.5	13.6	11.7

### Capacity Correction Factors For Electric and Hot Gas Defrost Units

Saturated Suction Temperature °F	+20	-10	-20	-30
Saturated Suction Temperature °C	-7	-23	-29	-34
Multiply Capacity By	1.15	1.04	1.00	0.90

## LCE6/LCE4 Electric Defrost Models 60 Hz. with PSC Motors



LCE6/LCE4 Model Size	Capacity BTUH / Watts 10°F / 6°C TD -20°F / -29°C SST		Fan Data		PSC, PSC-TE Motor Data (Total Amps/Watts)					Defrost Heaters (Total Amps)				
			CFM / m <sup>3</sup> H	No.	HP	208-230/ 1/60 Watts		460/ 1/60 Watts		Watts	230/ 1/60	230/ 3/60	460/ 1/60	
	1/15	1/60				1/60	1/60							
<b>6 FPI Models</b>														
LCE635	3,500	1,030	700	1,189	1	1/15	0.5	91	0.4	117	900	3.9	2.3	2.0
LCE643	4,300	1,260	650	1,104	1	1/15	0.5	91	0.4	117	900	3.9	2.3	2.0
LCE665	6,500	1,900	1,400	2,379	2	1/15	1.0	182	0.8	234	1800	7.8	4.5	3.9
LCE676	7,600	2,230	1,300	2,209	2	1/15	1.0	182	0.8	234	1800	7.8	4.5	3.9
LCE694	9,400	2,750	1,300	2,209	2	1/15	1.0	182	0.8	234	1800	7.8	4.5	3.9
LCE6120	12,000	3,520	2,100	3,568	3	1/15	1.5	273	1.2	351	2700	11.7	6.8	5.9
LCE6140	14,000	4,100	1,950	3,313	3	1/15	1.5	273	1.2	351	2700	11.7	6.8	5.9
LCE6160	16,000	4,690	2,600	4,418	4	1/15	2.0	364	1.6	468	3600	15.7	9.0	7.8
LCE6180	18,000	5,270	2,600	4,418	4	1/15	2.0	364	1.6	468	3600	15.7	9.0	7.8
LCE6200	20,000	5,860	3,250	5,522	5	1/15	2.5	455	2.0	585	4500	19.6	11.3	9.8
LCE6240	24,000	7,030	3,900	6,627	6	1/15	3.0	546	2.4	702	5400	23.5	13.6	11.7
LCE6270	27,000	7,900	3,900	6,627	6	1/15	3.0	546	2.4	702	5400	23.5	13.6	11.7
<b>4 FPI Models</b>														
LCE441	4,100	1,200	690	1,172	1	1/15	0.5	91	0.4	117	900	3.9	2.3	2.0
LCE457	5,700	1,670	1,440	2,447	2	1/15	1.0	182	0.8	234	1800	7.8	4.5	3.9
LCE467	6,700	1,960	1,380	2,345	2	1/15	1.0	182	0.8	234	1800	7.8	4.5	3.9
LCE482	8,200	2,400	1,380	2,345	2	1/15	1.0	182	0.8	234	1800	7.8	4.5	3.9
LCE4105	10,500	3,080	2,170	3,687	3	1/15	1.5	273	1.2	351	2700	11.7	6.8	5.9
LCE4139	13,900	4,070	2,760	4,690	4	1/15	2.0	364	1.6	468	3600	15.7	9.0	7.8
LCE4174	17,400	5,100	3,450	5,862	5	1/15	2.5	455	2.0	585	4500	19.6	11.3	9.8
LCE4208	20,800	6,090	4,140	7,035	6	1/15	3.0	546	2.4	702	5400	23.5	13.6	11.7
LCE4235	23,500	6,880	4,140	7,035	6	1/15	3.0	546	2.4	702	5400	23.5	13.6	11.7

# Hot Gas Defrost Capacities

## LCH6/LCH4 Hot Gas Defrost Models 60 Hz. with Shaded Pole Motors

LCH6/LCH4 Model Size	Capacity BTUH / Watts 10°F / 6°C TD -20°F / -29°C SST		Fan Data			Shaded Pole Motor Data (Total Amps/Watts)						Drain Pan Heater (Total Amps)*			
						HP	115/ 1/60 Watts		208-230/ 1/60 Watts		Watts	115/ 1/60	230/ 1/60	460/ 1/60	
			CFM / m³H	No.											
<b>6 FPI Models</b>															
LCH635	3,500	1,030	700	1,189	1	1/15	1.8	116	1.0	122	300	2.6	1.3	0.7	
LCH643	4,300	1,260	650	1,104	1	1/15	1.8	116	1.0	122	300	2.6	1.3	0.7	
LCH665	6,500	1,900	1,400	2,379	2	1/15	3.6	232	2.0	244	600	5.2	2.6	1.3	
LCH676	7,600	2,230	1,300	2,209	2	1/15	3.6	232	2.0	244	600	5.2	2.6	1.3	
LCH694	9,400	2,750	1,300	2,209	2	1/15	3.6	232	2.0	244	600	5.2	2.6	1.3	
LCH6120	12,000	3,520	2,100	3,568	3	1/15	5.4	348	3.0	366	900	7.8	3.9	2.0	
LCH6140	14,000	4,100	1,950	3,313	3	1/15	5.4	348	3.0	366	900	7.8	3.9	2.0	
LCH6160	16,000	4,690	2,600	4,418	4	1/15	7.2	464	4.0	488	1,200	10.4	5.2	2.6	
LCH6180	18,000	5,270	2,600	4,418	4	1/15	7.2	464	4.0	488	1,200	10.4	5.2	2.6	
LCH6200	20,000	5,860	3,250	5,522	5	1/15	9.0	580	5.0	610	1,500	13.0	6.5	3.3	
LCH6240	24,000	7,030	3,900	6,627	6	1/15	10.8	696	6.0	732	1,800	15.7	7.8	3.9	
LCH6270	27,000	7,900	3,900	6,627	6	1/15	10.8	696	6.0	732	1,800	15.7	7.8	3.9	
<b>4 FPI Models</b>															
LCH441	4,100	1,200	690	1,172	1	1/15	1.8	116	1.0	122	300	2.6	1.3	0.7	
LCH457	5,700	1,670	1,440	2,447	2	1/15	3.6	232	2.0	244	600	5.2	2.6	1.3	
LCH467	6,700	1,960	1,380	2,345	2	1/15	3.6	232	2.0	244	600	5.2	2.6	1.3	
LCH482	8,200	2,400	1,380	2,345	2	1/15	3.6	232	2.0	244	600	5.2	2.6	1.3	
LCH4105	10,500	3,080	2,170	3,687	3	1/15	5.4	348	3.0	366	900	7.8	3.9	2.0	
LCH4139	13,900	4,070	2,760	4,690	4	1/15	7.2	464	4.0	488	1,200	10.4	5.2	2.6	
LCH4174	17,400	5,100	3,450	5,862	5	1/15	9.0	580	5.0	610	1,500	13.0	6.5	3.3	
LCH4208	20,800	6,090	4,140	7,035	6	1/15	10.8	696	6.0	732	1,800	15.7	7.8	3.9	
LCH4235	23,500	6,880	4,140	7,035	6	1/15	10.8	696	6.0	732	1,800	15.7	7.8	3.9	

\* Optional with electric drain pan.

## LCH6/LCH4 Hot Gas Defrost Models 60 Hz. with PSC Motors



LCH6/LCH4 Model Size	Capacity BTUH / Watts 10°F / 6°C TD -20°F / -29°C SST		Fan Data			PSC, PSC-TE Motor Data (Total Amps/Watts)						Drain Pan Heater (Total Amps)				
						HP	115/ 1/60 Watts		208-230/ 1/60 Watts		460/ 1/60 Watts		Watts	115/ 1/60	230/ 1/60	460/ 1/60
			CFM / m³H	No.												
<b>6 FPI Models</b>																
LCH635	3,500	1,030	700	1,189	1	1/15	1.0	82	0.5	91	0.4	117	300	2.6	1.3	0.7
LCH643	4,300	1,250	650	1,104	1	1/15	1.0	82	0.5	91	0.4	117	300	2.6	1.3	0.7
LCH665	6,500	1,900	1,400	2,379	2	1/15	2.0	164	1.0	182	0.8	234	600	5.2	2.6	1.3
LCH676	7,600	2,230	1,300	2,209	2	1/15	2.0	164	1.0	182	0.8	234	600	5.2	2.6	1.3
LCH694	9,400	2,750	1,300	2,209	2	1/15	2.0	164	1.0	182	0.8	234	600	5.2	2.6	1.3
LCH6120	12,000	3,520	2,100	3,568	3	1/15	3.0	246	1.5	273	1.2	351	900	7.8	3.9	2.0
LCH6140	14,000	4,100	1,950	3,313	3	1/15	3.0	246	1.5	273	1.2	351	900	7.8	3.9	2.0
LCH6160	16,000	4,690	2,600	4,418	4	1/15	4.0	328	2.0	364	1.6	468	1,200	10.4	5.2	2.6
LCH6180	18,000	5,270	2,600	4,418	4	1/15	4.0	328	2.0	364	1.6	468	1,200	10.4	5.2	2.6
LCH6200	20,000	5,860	3,250	5,522	5	1/15	5.0	410	2.5	455	2.0	585	1,500	13.0	6.5	3.3
LCH6240	24,000	7,030	3,900	6,627	6	1/15	6.0	492	3.0	546	2.4	702	1,800	15.7	7.8	3.9
LCH6270	27,000	7,900	3,900	6,627	6	1/15	6.0	492	3.0	546	2.4	702	1,800	15.7	7.8	3.9
<b>4 FPI Models</b>																
LCH441	4,100	1,200	690	1,172	1	1/15	1.0	82	0.5	91	0.4	117	300	2.6	1.3	0.7
LCH457	5,700	1,670	1,440	2,447	2	1/15	2.0	164	1.0	182	0.8	234	600	5.2	2.6	1.3
LCH467	6,700	1,960	1,380	2,345	2	1/15	2.0	164	1.0	182	0.8	234	600	5.2	2.6	1.3
LCH482	8,200	2,400	1,380	2,345	2	1/15	2.0	164	1.0	182	0.8	234	600	5.2	2.6	1.3
LCH4105	10,500	3,080	2,170	3,687	3	1/15	3.0	246	1.5	273	1.2	351	900	7.8	3.9	2.0
LCH4139	13,900	4,070	2,760	4,690	4	1/15	4.0	328	2.0	364	1.6	468	1,200	10.4	5.2	2.6
LCH4174	17,400	5,100	3,450	5,862	5	1/15	5.0	410	2.5	455	2.0	585	1,500	13.0	6.5	3.3
LCH4208	20,800	6,090	4,140	7,035	6	1/15	6.0	492	3.0	546	2.4	702	1,800	15.7	7.8	3.9
LCH4235	23,500	6,880	4,140	7,035	6	1/15	6.0	492	3.0	546	2.4	702	1,800	15.7	7.8	3.9

\* Optional with electric drain pan.



## LCA6 Air Defrost Models 50 Hz. with PSC Motors

LCA6 Model Size	Capacity BTUH / Watts 6°C TD -4°C SST		Fan Data			PSC, TSC-TE Motor Data (Total Amps)						
			CFM / m³H		No.	HP	110/ 1/50 Watts		220/ 1/50 Watts		380/ 1/50 Watts	
LCA640	3,800	1,112	670	1,117	1	1/15	1.0	68	0.5	65	0.4	82
LCA651	4,845	1,417	630	1,071	1	1/15	1.0	68	0.5	65	0.4	82
LCA662	5,890	1,723	586	995	1	1/15	1.0	68	0.5	65	0.4	82
LCA672	6,840	2,001	1,315	2,234	2	1/15	2.0	136	1.0	130	0.8	164
LCA690	8,550	2,502	1,260	2,142	2	1/15	2.0	136	1.0	130	0.8	164
LCA6110	10,450	3,057	1,170	1,989	2	1/15	2.0	136	1.0	130	0.8	164
LCA6135	12,825	3,752	1,891	3,213	3	1/15	3.0	204	1.5	195	1.2	246
LCA6160	19,200	4,447	1,756	2,984	3	1/15	3.0	204	1.5	195	1.2	246
LCA6185	17,575	5,142	2,521	4,284	4	1/15	4.0	272	2.0	260	1.6	328
LCA6215	20,425	5,976	2,341	3,978	4	1/15	4.0	272	2.0	260	1.6	328
LCA6260	24,700	7,226	2,927	4,973	5	1/15	5.0	340	2.5	325	2.0	410
LCA6310	29,450	8,616	3,512	5,967	6	1/15	6.0	408	3.0	390	2.4	492
LCA6350	33,250	9,728	3,512	5,967	6	1/15	6.0	408	3.0	390	2.4	492



## LCE6/LCE4 Electric Defrost Models 50 Hz. with PSC Motors

LCE6/LCE4 Model Size	Capacity BTUH / Watts 6°C TD -29°C SST		Fan Data		PSC, PSC-TE Motor Data (Total Amps/Watts)				Defrost Heaters (Total Amps/Watts)					
			CFM / m³H		No.	HP	220/ 1/50 Watts		380/ 1/50 Watts		Watts	220/ 1/50	220/ 3/50	380/ 1/50
<b>6 FPI Models</b>														
LCE635	3,325	973	630	1,071	1	1/15	0.5	65	0.4	82	823	3.7	2.2	1.6
LCE643	4,085	1,195	586	995	1	1/15	0.5	65	0.4	82	823	3.7	2.2	1.6
LCE665	6,175	1,807	1,261	2,142	2	1/15	1.0	130	0.8	164	1,647	7.5	4.3	3.2
LCE676	7,220	2,112	1,171	1,989	2	1/15	1.0	130	0.8	164	1,647	7.5	4.3	3.2
LCE694	8,930	2,613	1,171	1,989	2	1/15	1.0	130	0.8	164	1,647	7.5	4.3	3.2
LCE6120	11,400	3,335	1,891	3,213	3	1/15	1.5	195	1.2	246	2,470	11.2	6.5	4.9
LCE6140	13,300	3,891	1,756	2,984	3	1/15	1.5	195	1.2	246	2,470	11.2	6.5	4.9
LCE6160	15,200	4,447	2,341	3,978	4	1/15	2.0	260	1.6	328	3,294	15.0	8.6	6.5
LCE6180	17,100	5,003	2,341	3,978	4	1/15	2.0	260	1.6	328	3,294	15.0	8.6	6.5
LCE6200	19,000	5,559	2,927	4,973	5	1/15	2.5	325	2.0	410	4,117	18.7	10.8	8.1
LCE6240	22,800	6,671	3,512	5,967	6	1/15	3.0	390	2.4	492	4,941	22.5	13.0	9.7
LCE6270	25,650	7,504	3,512	5,967	6	1/15	3.0	390	2.4	492	4,941	22.5	13.0	9.7
<b>4 FPI Models</b>														
LCE441	3,895	1,140	621	1,056	1	1/15	0.5	65	0.4	82	823	3.7	2.2	1.6
LCE457	5,415	1,584	1,297	2,203	2	1/15	1.0	130	0.8	164	1,647	7.5	4.3	3.2
LCE467	6,365	1,862	1,243	2,111	2	1/15	1.0	130	0.8	164	1,647	7.5	4.3	3.2
LCE482	7,790	2,279	1,243	2,111	2	1/15	1.0	130	0.8	164	1,647	7.5	4.3	3.2
LCE4105	9,975	2,918	1,954	3,320	3	1/15	1.5	195	1.2	246	2,470	11.2	6.5	4.9
LCE4139	13,205	3,863	2,485	4,223	4	1/15	2.0	260	1.6	328	3,294	15.0	8.6	6.5
LCE4174	16,530	4,836	3,107	5,279	5	1/15	2.5	325	2.0	410	4,117	18.7	10.8	8.1
LCE4208	19,760	5,781	3,728	6,334	6	1/15	3.0	390	2.4	492	4,941	22.5	13.0	9.7
LCE4235	22,325	6,532	3,728	6,334	6	1/15	3.0	390	2.4	492	4,941	22.5	13.0	9.7

## LCH6/LCH4 Hot Gas Defrost Models 50 Hz. with PSC Motors

LCH6/LCH4 Model Size	Capacity BTUH / Watts 6°C TD -29°C SST		Fan Data		PSC, PSC-TE Motor Data (Total Amps/Watts)							Defrost Heaters (Total Amps)*				
			CFM / m³H	No.	HP	110/ 1/50 Watts	220/ 1/50 Watts	380/ 1/50 Watts	Watts	110/ 1/50	220/ 3/50	380/ 1/50				
<b>6 FPI Models</b>																
LCH635	3,325	973	630	1,070	1	1/15	1.0	68	0.5	65	0.4	82	275	2.5	1.3	0.6
LCH643	4,085	1,195	586	995	1	1/15	1.0	68	0.5	65	0.4	82	275	2.5	1.3	0.6
LCH665	6,175	1,802	1,261	2,142	2	1/15	2.0	136	1.0	130	0.8	164	549	5.0	2.5	1.1
LCH676	7,220	2,112	1,171	1,989	2	1/15	2.0	136	1.0	130	0.8	164	549	5.0	2.5	1.1
LCH694	8,930	2,613	1,171	1,989	2	1/15	2.0	136	1.0	130	0.8	164	549	5.0	2.5	1.1
LCH6120	11,400	3,335	1,891	3,213	3	1/15	3.0	204	1.5	195	1.2	246	823	7.5	3.7	1.6
LCH6140	13,300	3,891	1,756	2,984	3	1/15	3.0	204	1.5	195	1.2	246	823	7.5	3.7	1.6
LCH6160	15,200	4,447	2,341	3,978	4	1/15	4.0	272	2.0	260	1.6	328	1098	10.0	5.0	2.2
LCH6180	17,100	5,003	2,341	3,978	4	1/15	4.0	272	2.0	260	1.6	328	1098	10.0	5.0	2.2
LCH6200	19,000	5,559	2,927	4,973	5	1/15	5.0	340	2.5	325	2.0	410	1372	12.5	6.2	2.7
LCH6240	22,800	6,671	3,512	5,967	6	1/15	6.0	408	3.0	390	2.4	492	1649	15.0	7.5	3.2
LCH6270	25,650	7,504	3,512	5,967	6	1/15	6.0	408	3.0	390	2.4	492	1649	15.0	7.5	3.2
<b>4 FPI Models</b>																
LCH441	3,895	1,140	621	1,056	1	1/15	1.0	68	0.5	65	0.4	82	275	2.5	1.3	0.6
LCH457	5,415	1,584	1,297	2,203	2	1/15	2.0	136	1.0	130	0.8	164	549	5.0	2.5	1.1
LCH467	6,365	1,862	1,243	2,111	2	1/15	2.0	136	1.0	130	0.8	164	549	5.0	2.5	1.1
LCH482	7,790	2,279	1,243	2,111	2	1/15	2.0	136	1.0	130	0.8	164	549	5.0	2.5	1.1
LCH4105	9,975	2,918	1,954	3,320	3	1/15	3.0	204	1.5	195	1.2	246	823	7.5	3.7	1.6
LCH4139	13,205	3,863	2,485	4,223	4	1/15	4.0	272	2.0	260	1.6	328	1098	10.0	5.0	2.2
LCH4174	16,530	4,836	3,107	5,279	5	1/15	5.0	340	2.5	325	2.0	410	1372	12.5	6.2	2.7
LCH4208	19,760	5,781	3,728	6,334	6	1/15	6.0	408	3.0	390	2.4	492	1649	15.0	7.5	3.2
LCH4235	22,325	6,532	3,728	6,334	6	1/15	6.0	408	3.0	390	2.4	492	1649	15.0	7.5	3.2

\* Optional with electric drain pan.

## Air Defrost Physical Data

LCA6 Model Size	No. of Fans	Connections (Inches)				Approx. Net Wt. Lbs / kg	
		Coil Inlet	Suction	External Equalizer	Drain		
LCA640	1	1/2 OD	5/8 ID	1/4 OD	3/4 MPT	28	13
LCA651	1	1/2 OD	5/8 ID	1/4 OD	3/4 MPT	31	15
LCA662	1	1/2 OD	7/8 ID	1/4 OD	3/4 MPT	34	16
LCA672	2	1/2 OD	7/8 ID	1/4 OD	3/4 MPT	45	21
LCA690	2	1/2 OD	7/8 ID	1/4 OD	3/4 MPT	49	23
LCA6110	2	1/2 OD	7/8 ID	1/4 OD	3/4 MPT	51	24
LCA6135	3	1/2 OD	7/8 ID	1/4 OD	3/4 MPT	67	31
LCA6160	3	1/2 OD	7/8 ID	1/4 OD	3/4 MPT	69	32
LCA6185	4	1/2 OD	1 1/8 ID	1/4 OD	3/4 MPT	82	38
LCA6215	4	1/2 OD	1 1/8 ID	1/4 OD	3/4 MPT	84	39
LCA6260	5	1/2 OD	1 1/8 ID	1/4 OD	3/4 MPT	103	47
LCA6310	6	1/2 OD	1 1/8 ID	1/4 OD	3/4 MPT	124	57
LCA6350	6	1/2 OD	1 3/8 ID	1/4 OD	3/4 MPT	127	58

## Electric Defrost Physical Data

LCE6/LCE4 Model Size	No. of Fans	Connections (Inches)				Approx. Net Wt. Lbs / kg	
		Coil InLCE	Suction	External Equalizer	Drain		
<b>6 FPI Models</b>							
LCE635	1	1/2 OD	5/8 ID	1/4 OD	3/4 MPT	24	11
LCE643	1	1/2 OD	5/8 ID	1/4 OD	3/4 MPT	29	14
LCE665	2	1/2 OD	5/8 ID	1/4 OD	3/4 MPT	43	20
LCE676	2	1/2 OD	7/8 ID	1/4 OD	3/4 MPT	45	21
LCE694	2	1/2 OD	7/8 ID	1/4 OD	3/4 MPT	48	22
LCE6120	3	1/2 OD	7/8 ID	1/4 OD	3/4 MPT	60	28
LCE6140	3	1/2 OD	7/8 ID	1/4 OD	3/4 MPT	62	29
LCE6160	4	1/2 OD	1 1/8 ID	1/4 OD	3/4 MPT	81	37
LCE6180	4	1/2 OD	1 1/8 ID	1/4 OD	3/4 MPT	84	39
LCE6200	5	1/2 OD	1 1/8 ID	1/4 OD	3/4 MPT	101	46
LCE6240	6	1/2 OD	1 1/8 ID	1/4 OD	3/4 MPT	121	55
LCE6270	6	1/2 OD	1 1/8 ID	1/4 OD	3/4 MPT	124	57
<b>4 FPI Models</b>							
LCE441	1	1/2 OD	5/8 ID	1/4 OD	3/4 MPT	28	13
LCE457	2	1/2 OD	7/8 ID	1/4 OD	3/4 MPT	42	19
LCE467	2	1/2 OD	7/8 ID	1/4 OD	3/4 MPT	44	20
LCE482	2	1/2 OD	7/8 ID	1/4 OD	3/4 MPT	47	22
LCE4105	3	1/2 OD	7/8 ID	1/4 OD	3/4 MPT	59	27
LCE4139	4	1/2 OD	1 1/8 ID	1/4 OD	3/4 MPT	80	37
LCE4174	5	1/2 OD	1 1/8 ID	1/4 OD	3/4 MPT	100	46
LCE4208	6	1/2 OD	1 1/8 ID	1/4 OD	3/4 MPT	120	55
LCE4235	6	1/2 OD	1 1/8 ID	1/4 OD	3/4 MPT	123	56

## Hot Gas Defrost Physical Data

LCH6/LCH4 Model Size	No. of Fans	Connections (Inches)					Hot Gas Pan Conns.*	Approx. Net Wt. Lbs / kg	
		Coil Inlet	Suction	External Equalizer	Drain	Side Port			
<b>6 FPI Models</b>									
LCH635	1	5/8 ODF	5/8 ID	1/4 OD	3/4 MPT	3/8 OD	5/8 OD/ID	26	12
LCH643	1	5/8 ODF	5/8 ID	1/4 OD	3/4 MPT	3/8 OD	5/8 OD/ID	31	15
LCH665	2	5/8 ODF	5/8 ID	1/4 OD	3/4 MPT	3/8 OD	5/8 OD/ID	45	21
LCH676	2	5/8 ODF	7/8 ID	1/4 OD	3/4 MPT	3/8 OD	5/8 OD/ID	47	22
LCH694	2	7/8 ODF	7/8 ID	1/4 OD	3/4 MPT	3/8 OD	5/8 OD/ID	50	23
LCH6120	3	7/8 ODF	7/8 ID	1/4 OD	3/4 MPT	3/8 OD	5/8 OD/ID	62	29
LCH6140	3	7/8 ODF	7/8 ID	1/4 OD	3/4 MPT	3/8 OD	5/8 OD/ID	64	30
LCH6160	4	7/8 ODF	1 1/8 ID	1/4 OD	3/4 MPT	3/8 OD	5/8 OD/ID	83	38
LCH6180	4	1 1/8 ODF	1 1/8 ID	1/4 OD	3/4 MPT	3/8 OD	5/8 OD/ID	86	40
LCH6200	5	1 1/8 ODF	1 1/8 ID	1/4 OD	3/4 MPT	3/8 OD	5/8 OD/ID	103	47
LCH6240	6	1 1/8 ODF	1 1/8 ID	1/4 OD	3/4 MPT	3/8 OD	5/8 OD/ID	123	56
LCH6270	6	1 1/8 ODF	1 1/8 ID	1/4 OD	3/4 MPT	3/8 OD	5/8 OD/ID	126	57
<b>4 FPI Models</b>									
LCH441	1	5/8 ODF	5/8 ID	1/4 OD	3/4 MPT	3/8 OD	5/8 OD/ID	30	14
LCH457	2	5/8 ODF	7/8 ID	1/4 OD	3/4 MPT	3/8 OD	5/8 OD/ID	44	20
LCH467	2	5/8 ODF	7/8 ID	1/4 OD	3/4 MPT	3/8 OD	5/8 OD/ID	46	21
LCH482	2	5/8 ODF	7/8 ID	1/4 OD	3/4 MPT	3/8 OD	5/8 OD/ID	49	23
LCH4105	3	7/8 ODF	7/8 ID	1/4 OD	3/4 MPT	3/8 OD	5/8 OD/ID	61	28
LCH4139	4	7/8 ODF	1 1/8 ID	1/4 OD	3/4 MPT	3/8 OD	5/8 OD/ID	82	38
LCH4174	5	7/8 ODF	1 1/8 ID	1/4 OD	3/4 MPT	3/8 OD	5/8 OD/ID	102	47
LCH4208	6	7/8 ODF	1 1/8 ID	1/4 OD	3/4 MPT	3/8 OD	5/8 OD/ID	122	56
LCH4235	6	1 1/8 ODF	1 1/8 ID	1/4 OD	3/4 MPT	3/8 OD	5/8 OD/ID	125	57

The standard design for the Larkin Low Profile Evaporators will incorporate an efficient hot gas loop in the drain pan. Utilizing a hot gas loop is ideal for hot gas defrost applications where high temperature gas can be maintained to defrost both the evaporator drain pan and coil. For these models, an insulated drain pan is standard.

For applications where cooler (lower) temperature hot gas is used for defrosting, Larkin offers optional electric heater elements in the drain pan to ensure quick and efficient defrost of the drain pan allowing condensate to drain quickly, saving the hot gas for efficient evaporator coil defrost.

If the optional electric heating element drain pan is preferred, please specify when ordering, there is no additional charge.

**\* Hot Gas Loop Piping Connections**

- For reverse cycle defrost piping:
  - 5/8 ID Inlet
  - 5/8 OD Outlet
- For 3 pipe defrost piping:
  - 5/8 OD Inlet
  - 5/8 ID Outlet

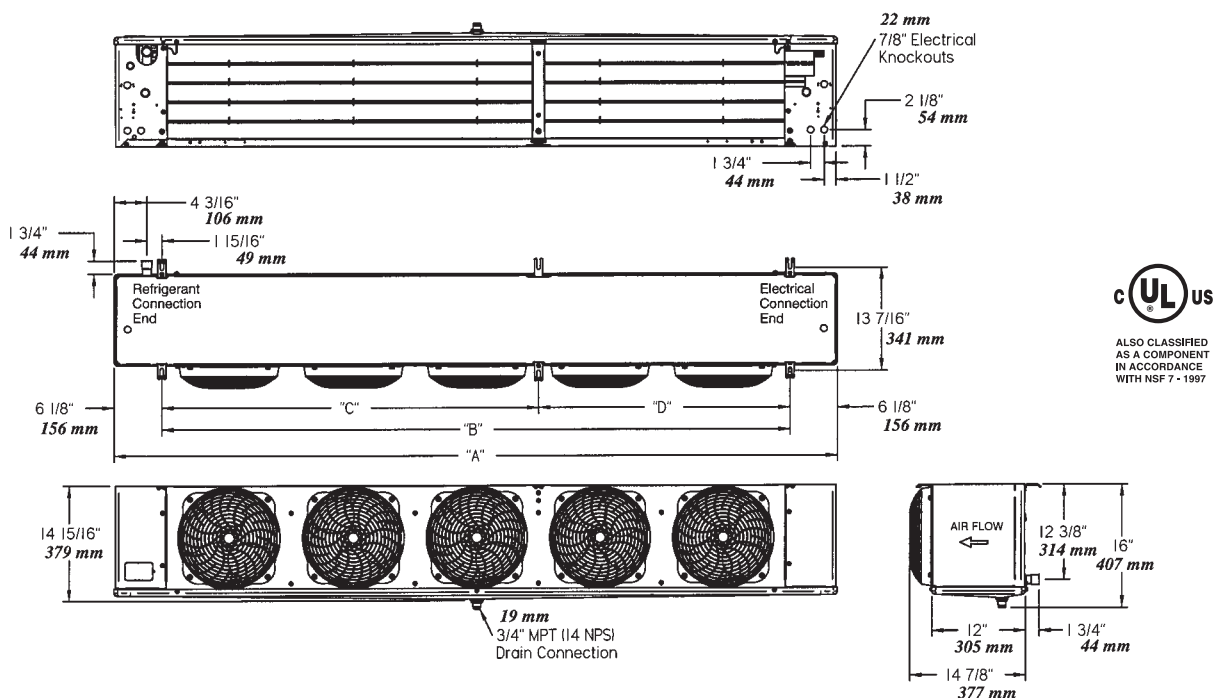

## Dimensional Data For All Models

Air Defrost Models	Electric and Hot Gas Defrost Models		No. of Fans	Dimensions (Inches / mm)			
	6 FPI	4 FPI		A	B	C	D
640	—	—	1	29.50	17.25	—	—
				<b>749.3</b>	<b>438.2</b>		
651	635	—	1	29.50	17.25	—	—
				<b>749.3</b>	<b>438.2</b>		
662	643	441	1	29.50	17.25	—	—
				<b>749.3</b>	<b>438.2</b>		
672	—	—	2	45.50	33.25	—	—
				<b>1,155.7</b>	<b>844.6</b>		
—	665	457	2	45.50	33.25	—	—
				<b>1,155.7</b>	<b>844.6</b>		
690	—	—	2	45.50	33.25	—	—
				<b>1,155.7</b>	<b>844.6</b>		
6110	676	467	2	45.50	33.25	—	—
				<b>1,155.7</b>	<b>844.6</b>		
—	694	482	2	45.50	33.25	—	—
				<b>1,155.7</b>	<b>844.6</b>		
—	6120	4105	3	61.50	49.25	—	—
				<b>1,562.1</b>	<b>1,251.0</b>		
6135	—	—	3	61.50	49.25	—	—
				<b>1,562.1</b>	<b>1,251.0</b>		
6160	6140	—	3	61.50	49.25	—	—
				<b>1,562.1</b>	<b>1,251.0</b>		
6185	6160	—	4	77.50	65.25	—	—
				<b>1,968.5</b>	<b>1,657.4</b>		
6215	6180	4139	4	77.50	65.25	—	—
				<b>1,968.5</b>	<b>1,657.4</b>		
6260	6200	4174	5	93.50	81.25	48.63	32.63
				<b>2,374.9</b>	<b>2,063.8</b>	<b>1,235.2</b>	<b>828.8</b>
6310	6240	4208	6	109.50	97.25	48.63	48.63
				<b>2,781.3</b>	<b>2,470.2</b>	<b>1,235.2</b>	<b>1,235.2</b>
6350	6270	4235	6	109.50	97.25	48.63	48.63
				<b>2,781.3</b>	<b>2,470.2</b>	<b>1,235.2</b>	<b>1,235.2</b>

NOTE: Hanger brackets will accept 3/8" / 9.5 mm hanger rods.

# Standard Nozzle Selection

## Air Defrost

Fan #	Model	Distributor Tube (inches)		# Circuits	R404A	R-22
		OD	Length			
1	640	3/16	15	1	-	-
1	651	3/16	15	1	-	-
1	662	3/16	15	2	L-1/2	L-1/3
2	672	3/16	15	2	L-1/2	L-1/3
2	690	3/16	15	3	L-3/4	L-1/2
2	6110	3/16	15	3	L-3/4	L-1/2
3	6135	3/16	15	5	L-1	L-3/4
3	6160	3/16	15	5	L-1 1/2	L-1
4	6185	3/16	15	5	L-1 1/2	L-1
4	6215	3/16	15	5	L-1-1/2	L-1
5	6260	3/16	15	9	L-2	L-1 1/2
6	6310	3/16	15	9	L-2 1/2	L-2
6	6350	3/16	15	10	L-2-1/2	L-2

## Electric Defrost

#Fans	Model	Distributor Tube (inches)		#Circuits	Low Temp. -30°F to 0°F SST		Medium Temp. +10°F to +25°F SST	
		OD	Length		R404A	R-22	R404A	R-22
<b>6 FPI</b>								
1	635	3/16	15	2	L-1/2	L-1/4	L-1/3	L-1/4
1	643	3/16	15	2	L-1/2	L-1/3	L-1/3	L-1/4
2	665	3/16	15	4	L-3/4	L-1/2	L-1/2	L-1/2
2	676	3/16	15	4	L-1	L-3/4	L-3/4	L-1/2
2	694	3/16	15	5	L-1	L-3/4	L-3/4	L-1/2
3	6120	3/16	15	5	L-1 1/2	L-1	L-1	L-3/4
3	6140	3/16	15	6	L-1 1/2	L-1	L-1 1/2	L-1
4	6160	3/16	15	8	L-2	L-1	L-1 1/2	L-1
4	6180	3/16	15	10	L-2	L-1 1/2	L-1 1/2	L-1
5	6200	3/16	15	9	L-2 1/2	L-1 1/2	L-2	L-1 1/2
6	6240	3/16	15	9	L-2 1/2	L-2	L-2	L-1 1/2
6	6270	3/16	15	10	L-3	L-2	L-2 1/2	L-2
<b>4 FPI</b>								
1	441	3/16	15	2	L-1/2	L-1/3	L-1/3	L-1/4
2	457	3/16	15	3	L-3/4	L-1/2	L-1/2	L-1/3
2	467	3/16	15	4	L-3/4	L-1/2	L-1/2	L-1/3
2	482	3/16	15	4	L-1	L-3/4	L-3/4	L-1/2
3	4105	3/16	15	5	L-1-1/2	L-3/4	L-1	L-3/4
4	4139	3/16	15	8	L-1 1/2	L-1	L-1-1/2	L-3/4
5	4174	3/16	15	8	L-2	L-1 1/2	L-1 1/2	L-1
6	4208	3/16	15	8	L-2 1/2	L-1 1/2	L-2	L-1 1/2
6	4235	3/16	15	10	L-2 1/2	L-2	L-2	L-1 1/2

## Hot Gas Defrost

#Fans	Model	Distributor Tube (inches)		#Circuits	Low Temp. -30°F to 0°F SST		Medium Temp. +10°F to +25°F SST	
		OD	Length		R404A	R-22	R404A	R-22
<b>6 FPI</b>								
1	635	1/4	15	2	J-1/2	J-1/4	J-1/3	J-1/4
1	643	1/4	15	2	J-1/2	J-1/3	J-1/3	J-1/4
2	665	1/4	15	4	J-1	J-1/2	J-3/4	J-1/3
2	676	1/4	15	4	J-1	J-3/4	J-3/4	J-1/2
2	694	1/4	15	5	G-1 1/2	G-3/4	G-3/4	G-1/2
3	6120	1/4	15	5	G-1 1/2	G-1	G-1	G-3/4
3	6140	1/4	15	6	G-2	G-1	G-1 1/2	G-1
4	6160	1/4	15	8	G-2	G-1 1/2	G-1 1/2	G-1
4	6180	1/4	15	10	E-2 1/2	E-1 1/2	E-1 1/2	E-1
5	6200	1/4	15	9	E-2 1/2	E-2	E-2	E-1 1/2
6	6240	1/4	15	9	E-3	E-2	E-2	E-1 1/2
6	6270	1/4	15	10	E-3	E-2	E-2 1/2	E-1-1/2
<b>4 FPI</b>								
1	441	1/4	15	2	J-1/2	J-1/3	J-1/3	J-1/4
2	457	1/4	15	3	J-3/4	J-1/2	J-1/2	J-1/3
2	467	1/4	15	4	J-1	J-1/2	J-3/4	J-1/2
2	482	1/4	15	4	J-1	J-3/4	J-3/4	J-1/2
3	4105	1/4	15	5	G-1 1/2	G-3/4	G-1	G-3/4
4	4139	1/4	15	8	G-2	G-1	G-1 1/2	G-1
5	4174	1/4	15	8	G-2	G-1 1/2	G-1 1/2	G-1
6	4208	1/4	15	8	G-2 1/2	G-2	G-2	G-1 1/2
6	4235	1/4	15	10	E-3	E-2	E-2	E-1 1/2

Ship Loose				Factory Installed		
TXV Bypass Assembly Kits				TXV Bypass Assembly Kits		
LCH 6 FPI	SQE/SBF	EG	HFESC	SQE/SBF	EG	HFESC
635 - 676	50169210	50169213	50169216	52733701	52733704	52733707
694 - 6160	50169211	50169214	50169217	52733702	52733705	52733708
6180-6270	50169212	50169215	50169218	52733703	52733706	52733709
LCH 4 FPI						
441 - 482	50169210	50169213	50169216	52733701	52733704	52733707
4105 - 4208	50169211	50169214	50169217	52733702	52733705	52733708
4235	50169212	50169215	50169218	52733703	52733706	52733709

Ship Loose			Factory Installed	
Drain Pan Loop Check Valve Kit	Suction Line Check Valve Kit		Drain Pan Loop Check Valve Kit	Suction Line Check Valve Kit
LCH 6 FPI				
635 - 665	50169304	50169604	52733601	52733801
676 - 6140	50169305	50169605	52733602	52733802
6160 - 6270	50169306	50169606	52733603	52733803
LCH 4 FPI				
441	50169304	50169604	52733601	52733801
457 - 4105	50169305	50169605	52733602	52733802
4139 - 4235	50169306	50169606	52733603	52733803

**Recommendation** is that both check valve kits are ordered: (For hot gas models with the hot gas loop drain pan ONLY)

**Note:** The drain pan check valve kit can be ordered as an independent item. But the suction line check valve kit must be ordered with the drain pan check valve kit in order to complete the piping.

**Note:** When using the HOT GAS units with a Hot Gas loop drain pan on 0°F applications and below, an insulated drain pan is required (comes standard when ordering).

The Hot Gas unit coolers can be used in reverse cycle hot gas defrost systems using multiple evaporators connected to one condensing unit. Generally, not more than one-third of the system defrosts at one time. During the reverse cycle defrost, the reversing valve, located in the compressor discharge line, diverts hot gas through the suction line to the evaporator. See piping view in Figure 1. The suction line check valve directs the hot gas through the drain pan loop which prevents condensate in the pan from freezing. The hot gas exits the loop at the pan loop outlet header and enters the evaporator through the check valve assembly. As the hot gas defrosts the coil, heat is removed from the hot gas and eventually it condenses into a liquid and exits the coil at the distributor sideport. The liquid then flows through the check valve of the thermostatic expansion valve bypass assembly, around the thermostatic expansion valve, and into the system liquid line. The liquid refrigerant then feeds other evaporators on the cooling cycle, evaporates, and returns to the compressor through their suction lines.

Figure 1 Reverse Cycle Piping

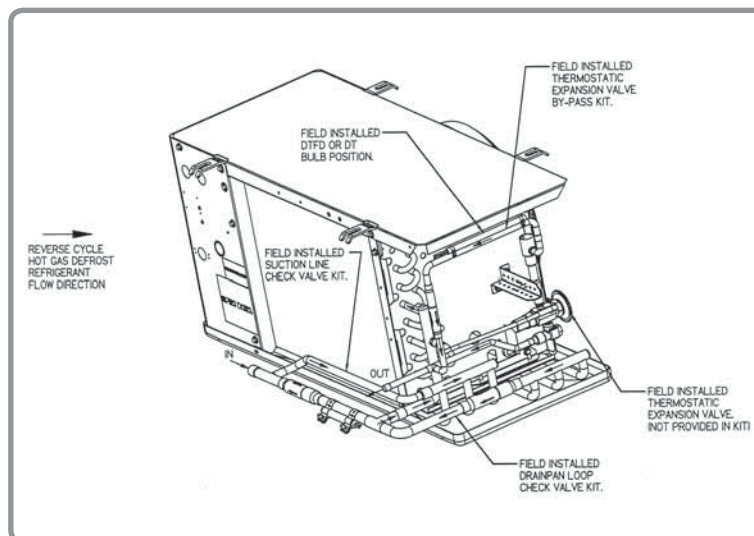

Figure 1 Reverse Cycle Piping

## Hot Gas Reverse Cycle Kits (cont.)

In the refrigeration cycle, the thermostatic expansion valve bypass assembly check valve only allows refrigerant flow through the thermostatic expansion valve and into the evaporator coil. As the refrigerant vapor exits the coil at the suction line, the check valve of the drain pan loop check valve assembly prevents the refrigerant vapor flow through the drain pan loop.

Factory engineered assemblies (kits) are available for both ship loose and factory installed at an additional cost to complete the reverse cycle piping and components. The suction line check valve assembly includes the suction line check valve and the piping for both the suction line and the connection to the drain pan loop inlet header. In order for the suction line check valve assembly to be mounted, the drain pan loop check valve assembly must be used. The drain pan loop check valve assembly includes the check valve, suction line tee and a bent pipe. The thermostatic expansion valve bypass assembly option includes the check valve, tee and necessary piping. In order for the thermostatic expansion valve bypass assembly option to be complete, a thermostatic expansion valve must be selected by the sales engineer. The thermostatic expansion valve bypass assembly option is dependent on the body style of the thermostatic expansion valves which includes the Sporlan SQE, SBF, EG and the Alco HFESC body styles. The factory installed thermostatic expansion valve bypass assembly option must have the thermostatic expansion valve selection included on the order for the Hot Gas unit cooler.

To increase the efficiency, higher performance and greater system protection, a heat exchanger may be beneficial to the system. In order to use a heat exchanger, the thermostatic expansion valve bypass assembly option must be modified. See the piping view in Figure 2. The modification includes rerouting the pipe from the thermostatic expansion valve bypass check valve to the inlet connection of the liquid line to the heat exchanger. A pipe needs to be routed from the liquid line outlet connection of the heat exchanger to the inlet connection of the thermostatic expansion valve.

The electrical control option includes an adjustable defrost termination and fan delay control (DTFD) which is standard. For an additional cost, an optional (2) control electrical system is available with one adjustable control for defrost termination (DT) and one fixed control for the fan delay (FD). For both the DTFD and DT adjustable controls, the remote bulb position is with the bulb strapped to the piping of the thermostatic expansion valve bypass assembly option between the distributor sideport and the check valve. When the thermostatic expansion valve bypass assembly is ship loose, the installer will need to position the remote bulb. When the thermostatic expansion valve bypass assembly is factory installed, the remote bulb should already be properly installed.

Figure 2. Typical Liquid Line Bypass Kit  
(Shown assembled and modified for heat exchanger)

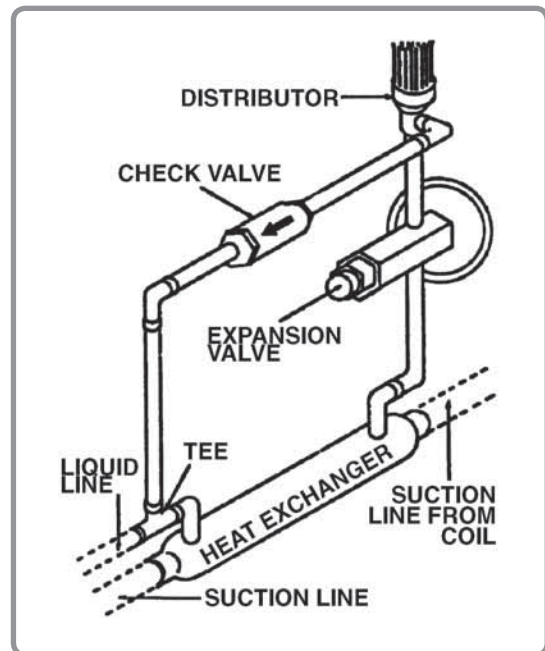
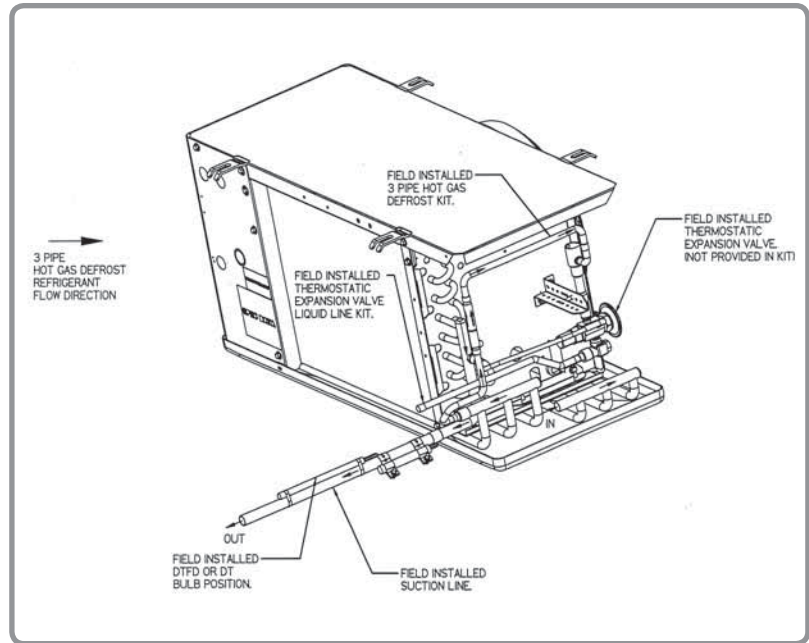

Figure 3 - 3-Pipe

The Hot Gas defrost unit cooler conforms to the standard 3-pipe hot gas system using a check valve assembly, an electrical control to terminate the defrost, and a hot gas solenoid valve. The check valve assembly transports the hot gas between the drain pan loop and the sideport distributor of the coil. The check valve assembly kit is available for ship loose or factory installed for an additional cost. The electrical control option includes an adjustable defrost termination and fan delay control (DTFD) which is standard. An optional (2) control electrical system is available with one adjustable control for defrost termination (DT) and one fixed control for the fan delay (FD) for an additional cost. For both the DTFD and DT adjustable controls, the remote bulb position is with the bulb strapped to the suction line to insure a complete defrost. The remote bulb is positioned by the installer. The hot gas solenoid valve must be ordered separately and will be ship loose. The thermostatic expansion valve could be ordered separately and ship loose or the thermostatic expansion valve could be factory installed with a liquid line for an additional cost. The liquid line is designed for the body styles of the Sporlan SQE, SBF, EG and the Alco HFESC thermostatic expansion valves. The thermostatic expansion valve needs to be selected by the sales engineer. In a typical 3-pipe hot gas defrost multiple evaporator system, the compressor discharge defrosts the evaporator. The liquid/vapor mixture of refrigerant after defrost, however, returns to the common suction line of the system. In order to provide sufficient re-evaporation of the liquid vapor mixture and sufficient heat for defrost, no more than one-third of the system should be defrosted at one time. Some means of control in the 3-pipe hot gas system should be supplied to regulate the large amount of liquid returning to the compressor, Refrigerant slugging can otherwise damage the compressor.



The hot gas solenoid valve must be ordered separately and will be ship loose. The thermostatic expansion valve could be ordered separately and ship loose or the thermostatic expansion valve could be factory installed with a liquid line for an additional cost. The liquid line is designed for the body styles of the Sporlan SQE, SBF, EG and the Alco HFESC thermostatic expansion valves. The thermostatic expansion valve needs to be selected by the sales engineer. In a typical 3-pipe hot gas defrost multiple evaporator system, the compressor discharge defrosts the evaporator. The liquid/vapor mixture of refrigerant after defrost, however, returns to the common suction line of the system. In order to provide sufficient re-evaporation of the liquid vapor mixture and sufficient heat for defrost, no more than one-third of the system should be defrosted at one time. Some means of control in the 3-pipe hot gas system should be supplied to regulate the large amount of liquid returning to the compressor, Refrigerant slugging can otherwise damage the compressor.

Ship Loose				Factory Installed		
TXV Liquid Line				TXV Liquid Line		
LCH 6 FPI	SQE/SBF	EG	HFESC	SQE/SBF	EG	HFESC
635 - 676	50169410	50169413	50169416	52733901	52733904	52733907
694 - 6160	50169411	50169414	50169417	52733902	52733905	52733908
6180 - 6270	50169412	50169415	50169418	52733903	52733906	52733909
LCH 4 FPI						
441 - 482	50169410	50169413	50169416	52733901	52733904	52733907
4105 - 4208	50169411	50169414	50169417	52733902	52733905	52733908
4235	50169412	50169415	50169418	52733903	52733906	52733909

For Hot Gas models with the Hot Gas loop drain pan only

When using the HOT GAS units with a hot gas loop drain pan on 0°F applications and below, an insulated drain pan is required (comes standard on those units).

Check Valve Kit	Ship Loose	Factory Installed
	Drain Pan Loop Check Valve Kit	Drain Pan Loop
HGT 6 FPI		
635 - 676	50169504	52739601
694 - 6160	50169505	52739602
6180 - 6270	50169506	52739603
HGT 4 FPI		
441 - 482	50169504	52739601
4105 - 4208	50169505	52739602
4235	50169506	52739603

# Replacement Parts

## Motor / Fan Blade / Fan Guards

Part #	Description	No. Fans
25300101	Motor 115/1/60 Shaded Pole	1 - 6
25300201	Motor 208-230/1/60 Shaded Pole	1 - 6
25309501	Motor 115/1/60/50 Totally Enclosed PSC (110/1/50)	1 - 6
25309601	Motor 208-230/1/60/50 Totally Enclosed PSC	1 - 6
25309701	Motor 460/1/60/50 Totally Enclosed PSC	1 - 6
25309801	Motor 208-230/1/60/50 PSC (220/1/50)	1 - 6
25308701	Motor 460/1/60/50 PSC (380/1/50)	1 - 6
5140C	Fan Blade	1 - 6
37000701	Fan Guard - Molded	1 - 6
37000601	Fan Guard - Wire	1 - 6
23104901	Motor mount used with 115 & 208-230V motors	1 - 6
23103301	Motor mount used with 460V motors	1 - 6

## Electrical Components

Part #	Description	No. Fans
22512601	Terminal Strip	1 - 6
5709L	Defrost Termination / Fan Delay - Klixon type	1 - 6
4267-W	Defrost Termination / Fan Delay - Adjustable type	1 - 6
4131Y	Room Thermostat	1 - 6
5708L	Heater Safety - Klixon type	1 - 6

## Cabinet Components

Part #	Description	No. of Fans
40480101	Painted Drain Pan Air Defrost	1
40480201	Painted Drain Pan Air Defrost	2
40480301	Painted Drain Pan Air Defrost	3
40480401	Painted Drain Pan Air Defrost	4
40480501	Painted Drain Pan Air Defrost	5
40480601	Painted Drain Pan Air Defrost	6
40481103	Outer Painted Drain Pan HG	1
40481203	Outer Painted Drain Pan HG	2
40481303	Outer Painted Drain Pan HG	3
40481403	Outer Painted Drain Pan HG	4
40481503	Outer Painted Drain Pan HG	5
40481603	Outer Painted Drain Pan HG	6
40480101	Inner Drain Pan HG	1
40480201	Inner Drain Pan HG	2
40480301	Inner Drain Pan HG	3
40480401	Inner Drain Pan HG	4
40480501	Inner Drain Pan HG	5
40480601	Inner Drain Pan HG	6
40880802	Access Panel - Elect	1 - 6
40880702	Access Panel - Refrig	1 - 6
40880902	Back Panel - Refrig	1 - 6
40881002	Back Panel - Elect	1 - 6
40881202	End Panel - Hot Gas Refrig	1 - 6
40480104	Painted Drain Pan - Electric Defrost	1
40480206	Painted Drain Pan - Electric Defrost	2
40480306	Painted Drain Pan - Electric Defrost	3
40480404	Painted Drain Pan - Electric Defrost	4
40480504	Painted Drain Pan - Electric Defrost	5
40480604	Painted Drain Pan - Electric Defrost	6



PSC Motors are an Energy Solutions option and are optimized to help you save money by increasing energy efficiency.

## Electric Defrost

Part #	Desc.	Voltage	No. Fans
Coil Heater			
24752001	300 W	208-230/1/60	1
24752002	600 W	208-230/1/60	2
24752003	900 W	208-230/1/60	3
24752004	1200 W	208-230/1/60	4
24752005	1500 W	208-230/1/60	5
24752006	1800 W	208-230/1/60	6
Bottom Coil Heater			
24752401	150W	208-230/1/60	1
24752402	300W	208-230/1/60	2
24752403	450W	208-230/1/60	3
24752404	600W	208-230/1/60	4
24752405	750W	208-230/1/60	5
24752406	900W	208-230/1/60	6
Drain Pan Heater			
24752501	150W	208-230/1/60	1
24752502	300W	208-230/1/60	2
24752503	450W	208-230/1/60	3
24752504	600W	208-230/1/60	4
24750205	750W	208-230/1/60	5
24750206	900W	208-230/1/60	6

## Hot Gas Defrost – Electric Drain Pan Option Drain Pan Heater (1 per unit)

Part #	Description	Voltage	No. Fans
24752101	300 W	115/1/60	1
24752102	600 W	115/1/60	2
24752103	900 W	115/1/60	3
24752104	1200 W	115/1/60	4
24752105	1500 W	115/1/60	5
24752106	1800 W	115/1/60	6
24752201	300 W	208-230/1/60	1
24752202	600 W	208-230/1/60	2
24752203	900 W	208-230/1/60	3
24752204	1200 W	208-230/1/60	4
24752205	1500 W	208-230/1/60	5
24752206	1800 W	208-230/1/60	6
24752301	300 W	460/1/60	1
24752302	600 W	460/1/60	2
24752303	900 W	460/1/60	3
24752304	1200 W	460/1/60	4
24752305	1500 W	460/1/60	5
24752306	1800 W	460/1/60	6

## Drain Fittings

Part #	Description	No. Fans
26914901	Drain Fitting Kit	1 - 6
50148802	Drain Fitting Elbow - Air	1 - 6
50148804	Drain Fitting Adapter - Air	1 - 6

No. Fans	Air Defrost	Electric & Hot Gas	
	6 FPI	6 FPI	4FPI
1	640-662	635-643	441
2	672-6110	665-694	457-482
3	6135-6160	6120-6140	4105
4	6185-6215	6160-6180	4139
5	6260	6200	4174
6	6310-6350	6240-6270	4208-4235



Visit our web site at [www.heatcraftpd.com](http://www.heatcraftpd.com) for Technical Literature Online.

Since product improvement is a continuing effort,  
we reserve the right to make changes in specifications without notice.



**A Brand of Heatcraft Refrigeration Products LLC**

2175 West Park Place Blvd. • Stone Mountain, GA 30087

770.465.5600 • Fax: 770.465.5990

[www.heatcraftpd.com](http://www.heatcraftpd.com)

